

SIG SAUER P229 SPORT Supplement

Removing the Compensator:

1. Remove the slide and recoil spring guide.
2. Unscrew and remove the Compensator Hex Screw (right side of unit).
3. Remove Hex Screw Spring.
4. Screw the provided threaded pin into the Wedge and pull Wedge out of Compensator. If Wedge is tight, screwing the pin further in will push the Wedge out of its seat in the Compensator.
5. Unscrew the Compensator from the Barrel.

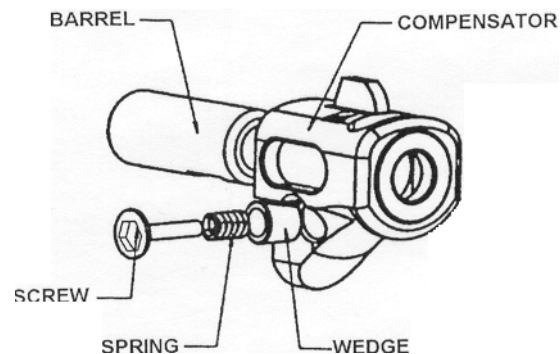

Installing the Compensator:

1. With Barrel in Slide, screw Compensator on Barrel fully, then back off until Compensator is flush (in-line) with slide.
2. Insert lightly lubricated Wedge (by using threaded pin) into Compensator Wedge Seat, slanted edge towards Barrel.
3. Remove threaded pin and insert Spring, then Fixing Screw.
4. Tighten hand tight only (do not over tighten).

Lubricate the guide rails of the frame with Tw25 or similar lubricant designed for Stainless Steel.